



**Australian Government**  
**Department of Agriculture**  
**and Water Resources**



**National Forest Service**  
**Papua New Guinea Forest Authority**

## COUNTRY SPECIFIC GUIDELINES FOR PAPUA NEW GUINEA



Timber processing and export in Papua New Guinea

This guideline has been prepared by the Australian Government and the Government of Papua New Guinea. It is intended to assist Australian importers of regulated timber products from Papua New Guinea in understanding the regulatory framework in Papua New Guinea in order for them to carry out their due diligence obligations under the *Illegal Logging Prohibition Regulation 2012*, which supports the *Illegal Logging Prohibition Act 2012*.

This guideline was co-endorsed by the Australian Government and the Government of Papua New Guinea on [date] 2015

## **Preface**

Australia's *Illegal Logging Prohibition Act 2012* identifies a number of measures to address the growing global problem of illegal logging and the related trade in illegal timber and wood products. Fundamental to the implementation of these measures is the ability to differentiate between legal and illegal timber. The definition of illegal logging has been a contentious issue because of differing country legislations and context.

Papua New Guinea, as a member to the International Tropical Timber Organisation (ITTO), recognises the ITTO definition on illegal logging of timber and wood products trade. ITTO's definition of Illegal logging refers to the "*removal of logs in a manner that is against the provisions of relevant laws [...of a particular country]*" (see: [www.itto.int/feature06\\_01/](http://www.itto.int/feature06_01/)).

This Country Specific Guideline (CSG) is intended to promote and strengthen legal timber trade between Papua New Guinea and Australia.

## **Disclaimer**

While reasonable efforts have been made to ensure that the contents of this guideline and the associated quick reference guide are factually correct, the Commonwealth of Australia does not accept responsibility for the accuracy or completeness of the contents and expressly disclaims liability for any loss or damage, however caused, that may be occasioned directly or indirectly through the use of, or reliance on, the contents of this guideline or associated quick reference guide.

## Contents

PREFACE	I
DISCLAIMER	I
CONTENTS	II
1. WHAT IS REQUIRED UNDER THE LAW?	1
2. PAPUA NEW GUINEA TIMBER PRODUCTS EXPORTED TO AUSTRALIA	2
3. IDENTIFYING LEGAL TIMBER PRODUCTS FROM PAPUA NEW GUINEA	3
3.1 Verifying legality of timber and wood products	3
3.2 Other initiatives promoting legally verifiable timber	4
4. HARVESTING REGULATIONS IN PAPUA NEW GUINEA	5
4.1 Legal requirements for timber harvesting and exports	5
4.1.1 Forest Management Agreement	5
4.1.2 Timber Authority	7
4.1.3 Forest Clearing Authority	8
4.2 Superseded Forest Management Arrangements	10
4.2.1 Timber Rights Purchase	10
4.2.2 Local Forest Area	10
5. BANNED TIMBER SPECIES FOR EXPORT IN ROUND LOG FORM	11
6. APPROVAL PROCESS FOR THE EXPORT OF LOGS AND WOOD PRODUCTS	12
6.1 Export application process	12
7. WHO SHOULD I CONTACT FOR FURTHER INFORMATION?	14
LIST OF ATTACHMENTS	15
ATTACHMENT A: LIST OF IDENTIFYING FEATURES ON OFFICIAL DOCUMENTS	16
ATTACHMENT B: TIMBER PERMIT (sample)	17
ATTACHMENT C: TIMBER LICENCE (sample)	18
ATTACHMENT D: EXPORT PERMIT FOR TIMBER – TYPE 1 (sample)	19
ATTACHMENT E: EXPORT LICENCE (sample)	20
ATTACHMENT F: EXPORT PERMIT FOR NON-TIMBER FOREST PRODUCTS – TYPE 2 (sample)	21
ATTACHMENT H: TIMBER AUTHORITY (Sample)	23
ATTACHMENT I: FOREST CLEARING AUTHORITY (Sample)	24
ATTACHMENT J: FLITCH - Definition and Illustration	25

## 1. What is required under the law?

Australia's *Illegal Logging Prohibition Act 2012* (the Act) restricts the movement of illegally logged timber into Australia for imported timber and timber products; and at timber processing mills for domestically grown raw logs.

The Act seeks to address the harmful environmental, social and economic impacts of illegal logging, including forest degradation, habitat loss and threats to sustainable livelihoods.

The Act defines 'illegally logged' as:

*'...in relation to timber, means harvested in contravention of laws in force in the place (whether or not in Australia) where the timber was harvested.'*

The *Illegal Logging Prohibition Regulation 2012* (the Regulation) prescribes due diligence for the regulated community, that is, Australian importers of regulated timber products (for the purposes of the Act - a regulated timber product is a product listed in Schedule 1 to the Regulation) and Australian processors of domestically grown raw logs. Under the Regulation, the regulated community has to undertake a due diligence process to minimise the risk of sourcing illegally logged timber.

Due diligence requirements for importers include the following steps:

**Step 1:** Information gathering

**Step 2:** Assessing and identifying risk against a timber legality framework (optional) or a country specific guideline (optional)

**Step 3:** Risk assessment (if required)

**Step 4:** Risk mitigation (if required)

Further information is available at the Australian Government Department of Agriculture and Water Resource's website ([www.agriculture.gov.au/illegallogging](http://www.agriculture.gov.au/illegallogging)).

This guideline is intended to assist an importer of regulated timber products from Papua New Guinea to comply with the due diligence requirements of the Regulation.

Information or evidence listed in this guideline is not an exhaustive list of evidence or documentation required to satisfy due diligence requirements under the Regulation. The Regulation should be referred to for the information required to be gathered to satisfy due diligence requirements.

Information gathered by applying this guideline, along with any other information gathered in accordance with the Regulation, needs to be assessed in accordance with the processes outlined in the Regulation to identify the risk that a regulated timber product is, is made from, or contains illegally logged timber.

## **2. Papua New Guinea timber products exported to Australia**

This country specific guideline shall be used as a tool to assist both timber exporters and importers within Papua New Guinea (PNG) and Australia in verifying legally sourced timber for trade between both countries.

The list of regulated timber products from PNG that are imported into Australian market are as follows:

1. plywood/plywood engineered wood products
2. sawn timber (assorted)/flitches
3. sawn balsawood and rubber wood
4. furniture/furniture components
5. mouldings and post/pole
6. minor forest products such as tree seeds.

**Note:** In the case of flitch: “A flitch is a large piece of timber having dimensions of more than 150 mm x 150 mm sawn or hewn on at least two (2) sides and docked to length at both ends, and free from wane and pith”.

Pieces of timber that contain wane and pith or core are considered to be ‘logs’.

Refer **Attachment I** for further information.

### 3. Identifying legal timber products from Papua New Guinea

#### 3.1 Verifying legality of timber and wood products

Timber exporters in PNG and timber importers in Australia should be familiar with the primary documents recognised by PNG relating to timber legality (identifying features of these documents are listed in **Attachment A**). These documents, as issued under the *Forestry Act 1991*, are as follows:

1. **Timber Permit** – issued by the Minister for Forests to the timber operator with conditions outlined for a specific Forest Management Agreement Area or a Local Forest Area to carryout forest management activities including harvesting by the timber operator (see **Attachment B**).
2. **Timber Licence** – issued by the National Forest Board (unless delegated to the PNGFA Managing Director) **only** to a registered Forest Industry Participant/ Consultant and provides the authority to engage in the forest industry activities specified in the **Timber Permit** or **Timber Authority** held by the participant. Once granted, a **Timber Licence** is valid for a term of 12 months only and is conditional based on licensee’s compliance with the terms and conditions of the **Timber Permit** or **Timber Authority**. The licence is also not transferable and shall not be amended at any time (see **Attachment C**).

In addition, the key documents that importers may request from suppliers to assist in the due diligence process are:

1. **Export Permit Type 1** – issued by the Minister for Forests following endorsement by the Papua New Guinea Forest Authority (PNGFA) for logs and wood products harvested from Timber Permit and Timber Licence areas (see **Attachment D**).
2. **Export Licence** – issued by the Minister for Trade, Commerce and Industry for round log export (see **Attachment E**).
3. **Export Permit Type 2** – issued by the Minister for Forests for non-timber forest products (e.g. balsawood, sandalwood, eaglewood, rattan etc) (see **Attachment F**).

The main difference between the two export permits is that the **Export Permit Type 1** is used for the export of major forest products such as timber harvested from authorised areas as indicted by the project name and export permit code and Timber Permit (TP)/ Timber Authority (TA)/ Local Forest Area (LFA)/ Forest Clearing Authority (FCA) number. The **Export Permit Type 2** is used for exports of minor forest products such as balsawood, sandalwood, eaglewood and rattan harvested from areas outside the main areas classified as TP/TA/LFA/FCA under a PNGFA licence, and therefore will not have an associated project name.

Aside from the documents highlighted above, copies of the following document may be requested to assist in demonstrating the legality of the timber product:

1. **Forest Industry Participant Certificate** - certifies that a proponent applying to carry out any forestry related activities has met all requirements to undertake these activities (see **Attachment G**).

### 3.2 Other initiatives promoting legally verifiable timber

The Government of Papua New Guinea recognises any internationally recognised timber products verification standards for use for timber and wood products trade and marketing. Timber exporters in Papua New Guinea and timber importers in Australia may refer to the following internationally recognised timber legality and verification schemes or frameworks to assist in meeting Australia’s due diligence requirements. Currently, these include:

1. The European Union Forest Law Enforcement Governance and Trade (FLEGT) licensing scheme for trade in timber products
2. The Forest Stewardship Council’s (FSC) Forest Management Certification Scheme
3. FSC Chain of Custody Certification
4. The Programme for the Endorsement of Forest Certification’s (PEFC) Sustainable Forest Management Certification
5. PEFC Chain of Custody Certification.

Papua New Guinea also recognises the following timber products verification standard; information against this standard may be used as part of your due diligence system.

1. PNG SGS Timber Legality and Traceability Verification\*.

**Table 1:** Certification schemes recognised for use in PNG.

Timber Legality Framework	Standards
<b>EU Forest Law Enforcement Governance and Trade</b>	<ul style="list-style-type: none"> <li>• FLEGT licensing scheme for trade in timber products</li> </ul>
<b>Forest Stewardship Council</b>	<ul style="list-style-type: none"> <li>• National Forest Management Standards for PNG</li> <li>• Standard for Chain of Custody Certification</li> <li>• Standard for Company Valuation of FSC Controlled Wood</li> <li>• FSC Controlled Wood Standard for Forest Management Enterprise</li> </ul>
<b>Programme for the Endorsement of Forest Certification’s</b>	<ul style="list-style-type: none"> <li>• Sustainable Forest Management Certification</li> <li>• Standard for Chain of Custody Certification</li> </ul>
<b>PNG SGS Timber Legality and Traceability Verification (TLTV)*</b>	<ul style="list-style-type: none"> <li>• PNG SGS Timber Legality and Traceability Verification</li> </ul>

**Note\*:** PNG SGS Timber Legality and Traceability Verification is not one of the pre-tested standards recognised in Schedule 2, Part 1 of the *Illegal Logging Prohibition Regulation 2012*.

## 4. Harvesting regulations in Papua New Guinea

The *Forestry Act 1991* provides the legislative basis for how PNG's forest resources are developed and managed, while the National Forest Policy (1991), National Forest Plan (1996) and the National Forestry Development Guidelines (2009) provide additional policy guidance. The two key documents issued under the *Forestry Act 1991* are the **Timber Permit** (see [Attachment B](#)) and **Timber Licence** (see [Attachment C](#)).

### 4.1 Legal requirements for timber harvesting and exports

The *Forestry Act 1991* places the responsibility of conservation and management of forests under the Ministry of Forests through the PNGFA. In PNG, the majority of forest resources are owned by the customary owners, a fact recognised in current forestry legislation that provides for the utilisation of these resources under three (3) different arrangements:

1. Forest Management Agreement (FMA)
2. Timber Authority (TA)
3. Forest Clearing Authority (FCA).

In addition, some harvesting activities are continuing to operate under the old arrangements, pursuant to the repealed forestry legislations:

1. Timber Rights Purchase (TRP)
2. Local Forest Area (LFA).

While these arrangements have been replaced with the three arrangements noted above (FMA, TA and FCA), existing TRP and LFA projects are currently provided for in the *Forestry Act 1991*. These arrangements will cease to be valid once the existing project arrangements expire.

#### 4.1.1 Forest Management Agreement

The **Forest Management Agreement** (FMA) (previously known as **Timber Rights Purchase** under the repealed legislation) is the major vehicle through which timber rights are acquired from customary owners.

Under the FMA process, the state acquires the rights to harvest timber from areas where customary owners are willing to transfer their timber rights. The state then issues a timber permit to a timber operator in accordance with established procedures to remove the timber on agreed terms and conditions, including the payment of royalties.

Under an FMA, the Minister for Forests is responsible for granting of a timber permit (see [Attachment B](#)) upon recommendation of the National Forest Board. This decision of the National Forest Board is based on the adequate completion of the prerequisites to issuing a timber permit which is part of requirements of the *Forestry Act 1991*. These requirements are generally known as the Thirty Four (34) steps for processing timber permit. For our purpose and to meet the requirements of the CSG, the 34 steps have been compacted to outline the main requirements, hence showing it as 31 steps process – see Figure 1 below.



**Figure 1: 31 Step Process – Forest Resource Acquisition and Allocation Process.**

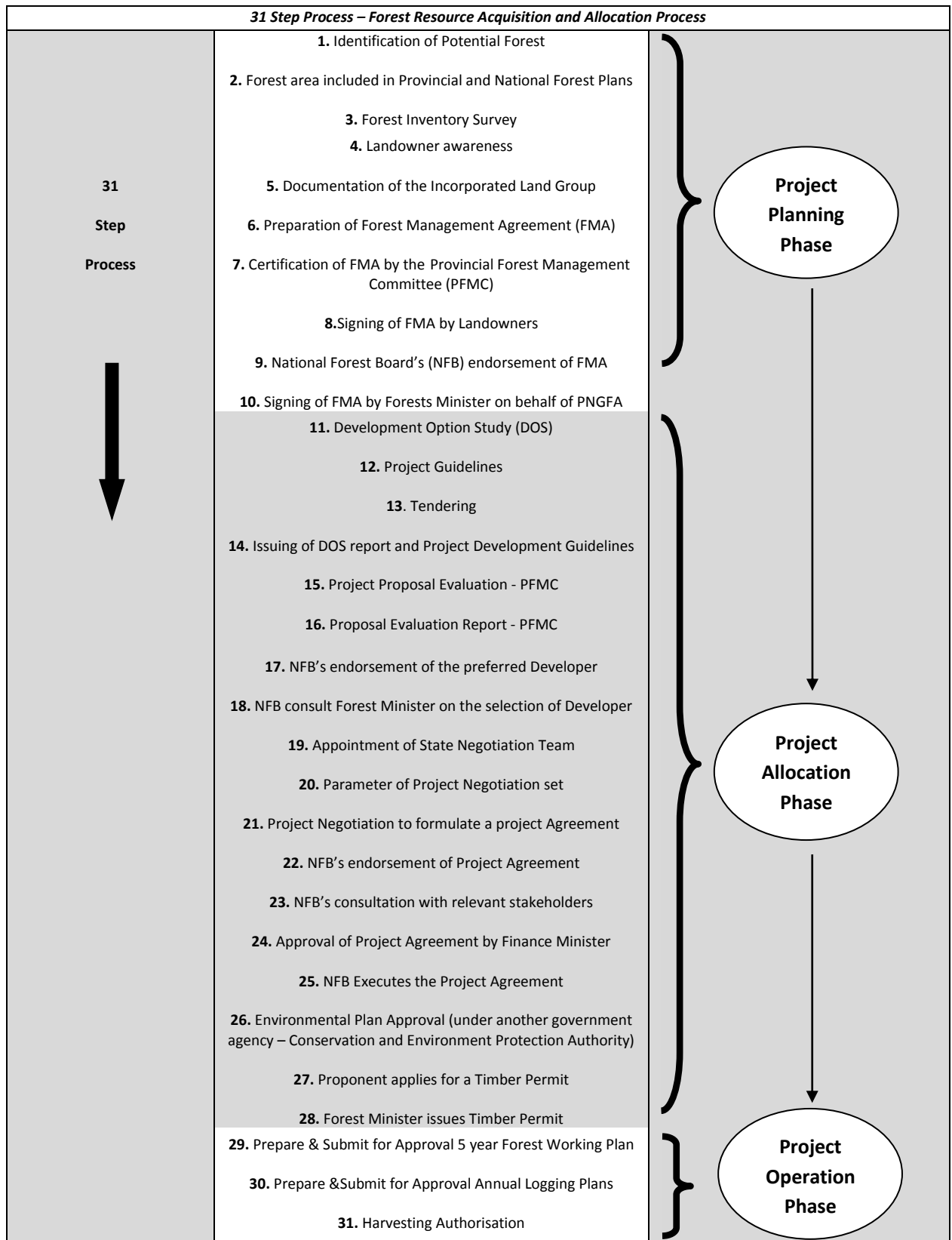

The Allocation and Acquisition process in described by the 31 steps in Figure 1, outlines the steps involved in finalising a timber project to become operational. Stakeholder consultation remains the main element in every step of the project planning, acquisition and allocation

process. These 31 steps apply only to FMA projects. In certain instances where an FMA area is in close proximity to an existing operating company, some of the steps are not required to be undertaken (e.g. advertisement), as the project serves as an extension to the existing project.

#### **4.1.2 Timber Authority**

The **Timber Authority** (TA) (see **Attachment H**) arrangements allows timber rights to be acquired without the requirement for the Development Option Study used for FMA allocations, therefore requiring less processing time by comparison. The TA arrangement is designed for small scale operations and can only be issued for areas that are not covered by a current FMA and for one of five specific forestry activities. The forestry activities covered under the various types of TA are:

1. TA-01: harvesting of less than 5,000 cubic metres annually of timber for domestic processing
2. TA-02: harvesting of timber for road line clearance
3. TA-03: harvesting of timber for clearing in preparation for agriculture or other land use
4. TA-04: harvesting of forest produce other than timber
5. TA-05: harvesting of timber in plantation area.

Only logs harvested under TA-02, TA-03 and TA-05 may be exported in log form (if the species is not otherwise subject to the log export ban), while minor forest products harvested under TA-04 can also be exported.

The TA assessment process commences with the submission of TA applications to the PNGFA Project Allocations Directorate for screening, prior to referral to the respective provincial government. Once referred to the provincial government, the Provincial Forest Management Committee (PFMC) evaluates the application. The Provincial Administrator, as the Chairman of the PFMC, makes a recommendation to the Provincial Chairman for Forestry Matters (usually the Provincial Minister for Forests) for endorsement. Once endorsed, the PFMC relays the decision of the Provincial Chairman for Forestry Matters to the National Forest Board (NFB) for its consent. If the NFB agrees to the PFMC's decisions and recommendations, it then informs the Provincial Chairman for Forestry matters through the PFMC accordingly. The Provincial Chairman for Forestry Matters, through the PFMC, approves and issues the TA. A bond fee is required within twenty-one (21) days of the TA's issuance before operations may start.

Figure 2 over the page illustrates the TA approval process.

**Figure 2:** Timber Authority Approval Process Component.

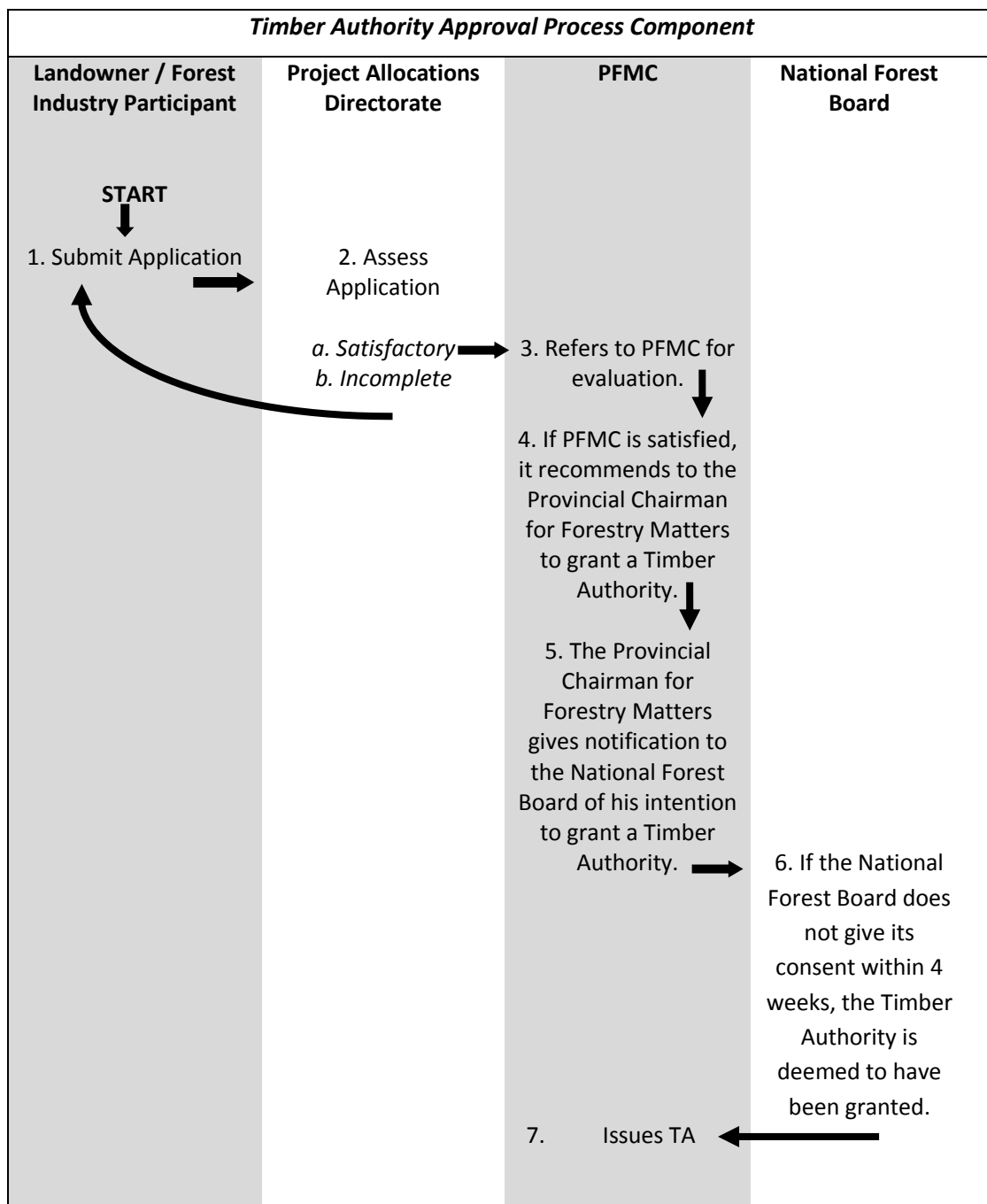

### 4.1.3 Forest Clearing Authority

The **Forest Clearing Authority (FCA)** (see **Attachment I**) was created in 2007 when section 90 of the *Forestry Act 1991* was amended to cater for large scale agricultural and infrastructural projects that involve the clearance of large tracts of forests. This amendment resulted in the creation of subsections 90A, 90B, 90C, 90D and 90E.

These amendments cover the following forestry activities:

1. 90A : enables large scale conversion of forest to agricultural or other land use over an area over 50 hectares
2. 90B: enables the process of clearing forest land for agricultural or other land use
3. 90C: enables large scale conversion of forest to road for over 12.5 km
4. 90D: describes the process for conversion of forest to road
5. 90E: prescribes the process of cancellation of a forest clearing authority.

Prior to the submission of a FCA to the NFB, the concerned applicant has to have appropriate approvals from the Department of Lands and Physical Planning (DLPP), Department of Agriculture and Livestock (DAL) and the Conservation and Environment Protection Authority (CEPA) (formerly the Department of Environment and Conservation).

In the case of approval from DLPP, the applicant must have proof that they have a duly registered title over the land for an agriculture development project. DAL evaluates the project proposal from the proponent against agricultural design and standards of the proposed project, thus making sure that it conforms to their process and a certificate of compliance is issued.

CEPA then appraise and issues the appropriate environmental permit after evaluation against their standards. In the case where an FCA is for road construction, appropriate approval must be granted by the Department of Works and Transport, agreeing that such a road is required and that its construction will be in line with an approved specification.

Once all the above approvals are in order, the applicant then submits its application to the PNGFA to go before the NFB. The following process then takes place:

1. An evaluation is undertaken against requirements of the *Forestry Act 1991*.
  - a. If all is in order, a referral is prepared to the respective PFMC for their due deliberations and endorsement.
2. The PFMC considers the application and provides its recommendation to the NFB on whether to endorse or reject the application
3. The application goes before the NFB for its deliberation in line with recommendations from the relevant PFMC.
  - a. If the application is considered satisfactory, the FCA is issued by the NFB.
    - i. The applicant is then given 21 days from the date of issuance to lodge its required performance bond.
  - b. If the application is not supported, the applicant is notified by an instrument of rejection.

The detailed FCA approval process is illustrated in Figure 3 over page.

**Figure 3:** Forest Clearing Authority Approval Process.

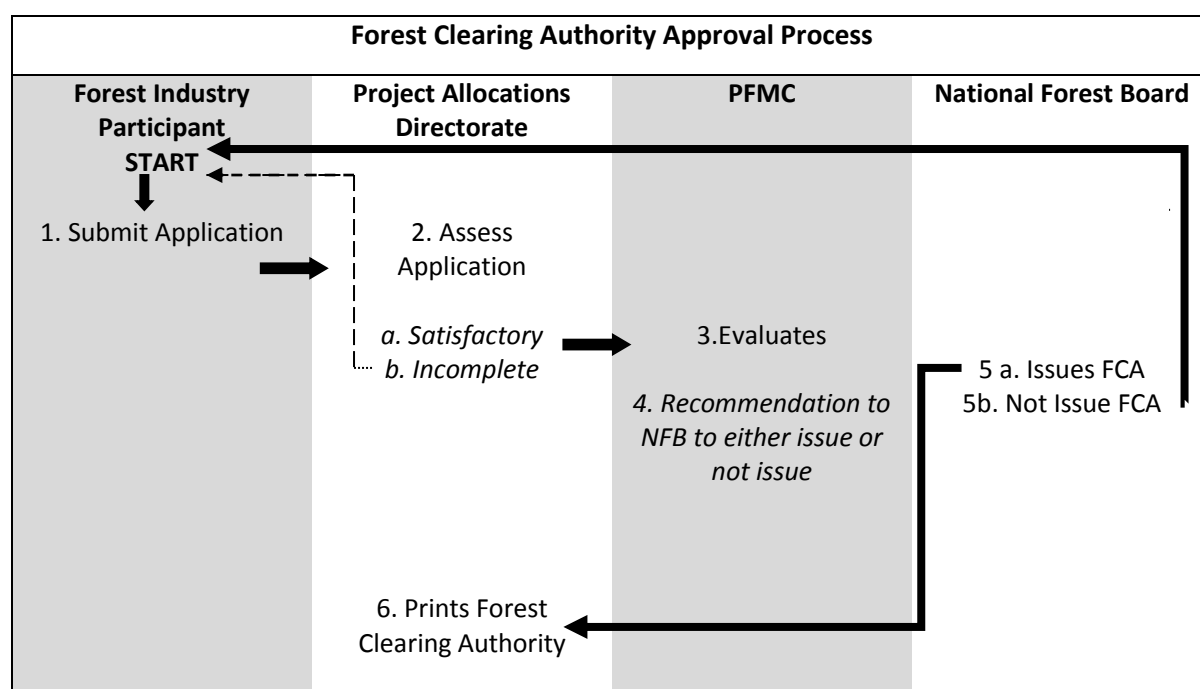

## 4.2 Superseded Forest Management Arrangements

As noted in Section 3.1, some harvesting activities are continuing to operate under older arrangements and are currently provided for in the *Forestry Act 1991*. These arrangements will no longer be valid once the existing project arrangements expire. Approximately 32 **Timber Rights Purchase** (TRP) Agreements are still current, with expiry dates ranging up until 2 December 2031. Another is the **Local Forest Area** (LFA) declaration. A brief description of each of these arrangements is as follows:

### 4.2.1 Timber Rights Purchase

Under this arrangement, the state acquires the rights to harvest timber from areas where customary owners are willing to transfer their timber rights. The state then issues a **Timber Permit** (TP) to a timber operator in accordance with established procedures to remove the timber on agreed terms and conditions, including the payment of royalties.

### 4.2.2 Local Forest Area

Under this arrangement, landowners are required to form and incorporate their landowner companies and enter into an agreement known as a 'private dealings' amongst themselves as landowners and the landowner company as a business entity. After signing the private dealings (agreements), the landowner's company then enters into a Logging and Marketing Agreement (LMA) with a contractor of their choice to conduct logging operations in the LFA project area. Logging will only commence once the Minister for Forests gives their consent.

## 5. Banned timber species for export in round log form

The PNG Government has banned a number of timber species from export in round log form due to their scarcity in the natural forest. However, these species may be exported as processed products. These banned timber species are listed in Table 1 below:

**Table 2:** Species banned from export in log form (Source: *Customs Tariff Act 1990*).

Common name/Trade name	Abbreviation	Botanical name
Kauri Pine	AGA	<i>Agathis sp.</i>
Hoop Pine	ARH	<i>Auracaria cunninghamii</i>
Klinkii Pine	ARK	<i>Auracaria hunsteinii</i>
Celery-Top Pine	CLP	<i>Phyllocladus hypophyllus</i>
Cordia	COR	<i>Cordia dichotoma</i>
Dacrydium	DAC	<i>Dacrydium nidulum</i>
Ebony	EBO	<i>Diospyros ferrea</i>
Kerosene wood	KEW	<i>Cordia subcordata</i>
Libocedrus	LIB	<i>Libocedrus pauanus</i>
Podocarp	POD	<i>Podocarpus sp.</i>
Brown Podocarp	POB	<i>Decussocarpus swalichianus</i>
Highland Podocarp	POH	<i>Dacrycarpus imbricatus</i>
Rosewood	ROS	<i>Pterocarpus indicus</i>
Balsa	BAL	<i>Ochroma lagopus</i>
Blackbean	BLB	<i>Castanospermum australe</i>

The export of any piece of timber from a species listed in **Table 1** larger than 150mm x 150mm that has *wane* and *pith* or *core* is banned from export, as they are considered to be 'logs'. The illustration of this description is in **Attachment J**.

## 6. Approval process for the export of logs and wood products

The approval process for the export of logs and other wood products from PNG requires exporters to apply for and obtain an **Export Permit Type 1** from the Minister for Forests (see [Attachment D](#)) and then an **Export Licence** from the Minister for Trade, Commerce and Industry (see [Attachment E](#)). Both an **Export Permit Type 1** and an **Export Licence** are required for round logs export. If an exporter is only exporting other wood products (i.e. processed wood products such as sawn timber, plywood, etc.), they only need to apply for an **Export Permit Type 1**. If an exporter is only exporting non-timber forest products (such as rattan), they only need to apply for an **Export Permit Type 2**. The granting of export permits is a delegated function under the *Customs Tariff Act 1990* to the Minister for Forests.

### 6.1 Export application process

All exporters are required to lodge an application to export logs and other wood products with the local PNGFA office to obtain an inspection report. The steps followed in exporting logs and wood products are shown in Figure 4 over page.

It is a requirement under section 41 of the *Forestry Act 1991* that a trained forester who is employed by the PNGFA must verify that the contents of the parcel are consistent with those items indicated in the **Export Permit Type 1** application (including timber species). The inspecting officer will also confirm that the logs and wood products nominated in the application have originated from an *authorised area*.

**Note:** An authorised area means any timber area which has a valid timber permit, Timber Authority and Forest Clearing Authority as issued by PNGFA. Any timber or wood products identified by the PNGFA inspecting officer as being sourced from non authorised areas would be considered illegal and appropriate measures under the *Forestry Act 1991* would be taken to confiscate them.

The inspection will also ensure that all statutory payments and other payments for the logs and other wood products have been made, by verifying all receipt for payment including timber royalties, levies and taxes (if any).

The inspection report should be attached with the application and submitted to the Export Administration Branch, PNGFA. All follow-up work and enquiries relating to applications are to be undertaken by the exporter.

Upon receiving an application for an export permit for logs and other wood products, the Export Administration Branch allocates a shipment identification or export permit number. This number is the reference used for the clearance, by PNG Customs, of the parcel of logs or other wood products for export.

The Export Administration Branch verifies that all documentation is in order and that the Free On Board (FOB) value of the parcel of logs and wood products is consistent with the prevailing export market value. In instances where the confirmation of the prevailing export market FOB value is not possible, a decision is made on these values based on the current indicative FOB values to respective markets.

**Figure 4: Export Application Process**

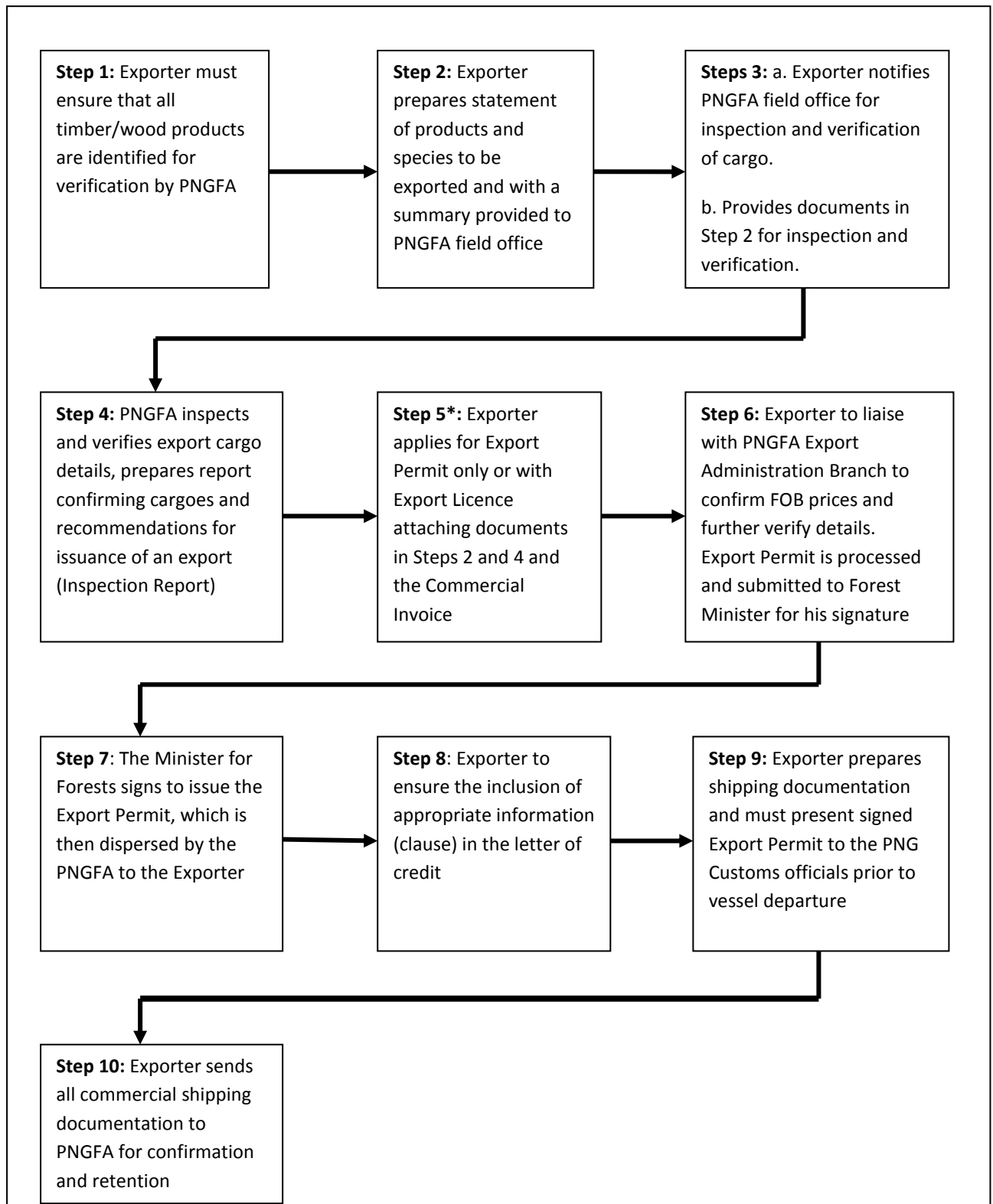

**Note\*:** An Export License is also required when exporter is exporting round logs.



## 7. Who should I contact for further information?



**Australian Government**  
**Department of Agriculture**  
**and Water Resources**

Australian Government

Department of Agriculture and Water  
Resources  
GPO Box 858  
Canberra ACT 2601  
Australia  
Phone: 1800 657 313 (free call in Australia)  
+61 2 6272 3933 (overseas callers)  
Web: [www.agriculture.gov.au/illegallogging](http://www.agriculture.gov.au/illegallogging)  
Email: [illegallogging@agriculture.gov.au](mailto:illegallogging@agriculture.gov.au)



**National Forest Service**  
**Papua New Guinea Forest Authority**

Papua New Guinea Forest Authority (PNGFA)

The Managing Director  
PO Box 5055  
Boroko, National Capital District  
Papua New Guinea  
Phone: +675 3277800  
Fax: +675 3254433  
Web [www.forestry.gov.pg](http://www.forestry.gov.pg)  
Email: [info\\_general@pngfa.gov.pg](mailto:info_general@pngfa.gov.pg)



Papua New Guinea Forest Industries  
Association (Inc.)

The Executive Officer  
PO Box 229  
Waigani, National Capital District  
Papua New Guinea  
Phone: +675 3259458  
Fax: +675 3259563  
Web: [www.fiapng.com](http://www.fiapng.com)  
Email: [bob@fiapng.com](mailto:bob@fiapng.com)

## List of Attachments

The listed Appendices below can be viewed from the PNGFA website - (www.forestry.gov.pg).

Attachment A: List of identifying features of official documents

Attachment B: Timber Permit (sample)

Attachment C: Timber Licence (sample)

Attachment D: Export Permit – Type 1 (sample)

Attachment E: Export Licence (sample)

Attachment F: Export Permit – Type 2 (sample)

Attachment G: Forest Industry Participant Certificate (sample)

Attachment H: Timber Authority (sample)

Attachment I: Forest Clearing Authority (sample)

Attachment J: Flitch definition and illustration

## ATTACHMENT A: LIST OF IDENTIFYING FEATURES ON OFFICIAL DOCUMENTS

Document	Identifying features
Timber Permit (Attachment A)	<ol style="list-style-type: none"> <li>1. Form Number (which is always 115)</li> <li>2. Timber Permit Number</li> <li>3. Name of the Forest Minister</li> <li>4. Signature of Forest Minister</li> </ol>
Timber Licence (Attachment B)	<ol style="list-style-type: none"> <li>1. Form Number (which is always 175)</li> <li>2. Licence Number</li> <li>3. Name of the Company</li> <li>4. Signature of the Managing Director of PNGFA</li> </ol>
Export Permit for Timber – Type 1 (Attachment C)	<ol style="list-style-type: none"> <li>1. Letterhead of the office of the Minister for Forests</li> <li>2. Export Permit Number</li> <li>3. Name of the Producer/Exporter</li> <li>4. Name of the wood product</li> <li>5. Official stamp of the Export Administration Branch of PNGFA</li> <li>6. Signature of the Forest Minister</li> </ol>
Export Licence (Attachment D)	<ol style="list-style-type: none"> <li>1. Form Number (which is always 1)</li> <li>2. Name of the Company</li> <li>3. PNGFA ID Number</li> <li>4. Registered Number of Licence</li> <li>5. Name of export licensing officer</li> <li>6. Official stamp of the Department of Commerce, Trade and Industry</li> </ol>
Export Permit for Non Timber Forest Products – Type 2 (Attachment E)	<ol style="list-style-type: none"> <li>1. Letterhead of the office of the Minister for Forest</li> <li>2. Export Permit Number</li> <li>3. Name of the Producer/Exporter</li> <li>4. Name of the wood product</li> <li>5. Official stamp of the Export Administration Branch of PNGFA</li> <li>6. Signature of the Forest Minister</li> </ol>
Forest Industry Participant (FIP) Certificate (Attachment F)	<ol style="list-style-type: none"> <li>1. Form Number (which is always 209)</li> <li>2. Name of the Company</li> <li>3. Forest Industry Participant Number</li> <li>4. Signature of the Managing Director of PNGFA</li> </ol>
Timber Authority (Attachment G)	<ol style="list-style-type: none"> <li>1. Form Number (which is always 155)</li> <li>2. Authority Number</li> <li>3. Project Area Name</li> <li>4. Proponent's name</li> <li>5. Forest Industry Participant Number</li> <li>6. Signature of the Chairman of Provincial Forestry Committee</li> </ol>
Forest Clearing Authority (Attachment H)	<ol style="list-style-type: none"> <li>1. Form Number (which is always 242)</li> <li>2. Forest Clearing Authority Number</li> <li>3. Proponent's name</li> <li>4. Forest Industry Participant Number</li> <li>5. Signature of authorised officer of the National Forest Board</li> </ol>

**ATTACHMENT B: TIMBER PERMIT (sample)**

**INDEPENDENT STATE OF PAPUA NEW GUINEA**

**FORESTRY ACT 1991**

Act, Sec. 73  
Reg. 118

FORM 115

**TIMBER PERMIT**

Permit No: PNGFA-TP14- [REDACTED]

I, **Hon. Patrick Pruaitch, MP Minister for Forests**, by virtue of the powers conferred by Section 73 of the Forestry Act 1991 and all other powers me enabling, grant a timber permit to [REDACTED] Ltd (in this permit referred to as "the holder").

This permit relates to the project area described in Schedule 1. Pursuant to or as conditions of this permit:

- (1) the amount of allowable cut is as specified in Schedule 2;
- (2) the term is as specified in Schedule 3 or no more than the term of any Forest Management Agreement relating to the project area (whichever is less);
- (3) where the term specified in paragraph (2) and Schedule 3 exceeds ten years, the term and conditions of this permit shall be reviewed by the Board after ten years and on the expiry of every successive period of five years;
- (4) the rates of royalties, levies and charges to be paid are as specified in Schedule 4;
- (5) the infrastructural requirements of this permit are as specified in the accompanying conditions or in Schedule 5;
- (6) this permit is subject to the provision of a performance bond for an amount specified in Schedule 6 which the holder shall lodge within 21 days with the Authority;
- (7) this permit relates to the project agreement specified in Schedule 7;
- (8) this permit is subject to the conditions prescribed in the Regulations;
- (9) this permit is subject to and conditional upon the holder throughout the period of the permit, observing and complying with all standards and practices as determined from time to time by the Authority including but not limited to the P.N.G. Logging Code of Practice, Procedures for Exporting Logs and Procedures for the identification, scaling and reporting (including royalty self-assessment) on logs harvested from Natural Forest Logging operations or any revisions or replacement documents thereof.

Dated this 13<sup>TH</sup> day of OCTOBER 2005.

  
MINISTER FOR FORESTS

NOTE: A PROJECT STATEMENT UNDER SECTION 100 OF THE ACT, A FIVE YEAR WORKING PLAN UNDER SECTION 101 OF THE ACT, AND AN ANNUAL LOGGING PLAN UNDER SECTION 102 OF THE ACT ARE REQUIRED TO BE SUBMITTED TO THE BOARD IN THE PRESCRIBED FORM BEFORE ANY RIGHTS IN THE TIMBER PERMIT MAY BE EXERCISED.

**ATTACHMENT C: TIMBER LICENCE (sample)**

INDEPENDENT STATE OF PAPUA NEW GUINEA  
FORESTRY ACT 1991

Act, Sec. 91  
Reg. 177

FORM 175

**LICENCE**

Licence No.: PNGFAL [REDACTED]

[REDACTED] LTD, a registered Forest Industry Participant (Reg. No. FI [REDACTED]) is hereby licensed to engage in the Forestry industry activities specified in Schedule 1.

This licence is granted for a term of 12 months commencing on the ..... day of ..... 2015 and is conditional on compliance by the licensee with the terms and conditions to which the activities authorised by this licence are related including but not limited to compliance with all standards and practices as determined from time to time by the Authority including but not limited to the P.N.G. Logging Code of Practice, the Procedures for Exporting Logs and the Procedures for the Identification, Scaling and Reporting (including Royalty Self-assessment) on Logs harvested from Natural Forest Logging Operations or any revisions or replacement documents thereof.

This licence is conditional upon the lodgement of a performance bond in accordance with Section 98 of the Act in an amount specified in Schedule 2.

The licensee shall comply with the terms and conditions contained in Schedule 3.

Date this 29<sup>th</sup> day of May 2015

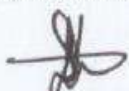
  
.....  
**DAVID DOTAONA**  
CHAIRMAN  
FOR THE BOARD

**SCHEDULE 1**

Forest activities to be conducted under this Licence: Purchasing, harvesting, processing and marketing of Balsa and in the location of the Gazelle Peninsula, **ENB Province**.

**SCHEDULE 2**

The amount of the performance bond is **K10,000.00** and must be renewed annually.

**SCHEDULE 3**

1. This Licence is issued strictly for Balsa activities only and not to be used to purchase and sell any other forest produce/products.
2. Application for Extension of the term of this Licence must be lodged with the Authority prior to the expiry date.

**ATTACHMENT D: EXPORT PERMIT FOR TIMBER - TYPE 1 (sample)**



# MINISTER FOR FORESTS

To: Manager  
Customs Office  
P.O. Box 215, MADANG  
Madang Province.

CUSTOMS (Prohibited Exports) REGULATION  
CHAPTER No. 101 (Reg. Sec:2)

Our file reference:

Wednesday, 29 October 2014

***Export Permit No. [REDACTED]***

I, Hon. Douglas Tomuriesa, MP and Minister For Forests hereby consent to the exports of the following forest produce.

Exporter: [REDACTED]  
Producer: [REDACTED]  
TP/TL/TA/LFA/FCA No: TA [REDACTED]  
Project: [REDACTED]  
Quantity (m3): 16,579 Sawn Kwi  
Value (USD): 17,175.60  
Species: As attached  
Loading Ports: Madang  
Vessel: Kokopo Chief  
Departure Date: 23-Nov-14  
Destination: Australia  
Buyer: [REDACTED] BRISBANE, Australia  
Export Licence:



*Hon. Douglas Tomuriesa MP,  
Minister for Forests*

PO BOX 5055, BOROKO, NATIONAL CAPITAL DISTRICT, PAPUA NEW GUINEA  
Telephone: (675) 327 7342 (Parliament) / 327 7918 / 920 (HQ Hohola)  
Facsimile: (675) 327 7480 (Parliament) / 325 5457 (HQ Hohola)

**ATTACHMENT E: EXPORT LICENCE (sample)**

**PAPUA NEW GUINEA**  
**EXPORTS (CONTROL & VALUATION) ORDINANCE 1973**  
 Application for an **ORDINARY** Licence to Export Goods

Form 1

Section 9  
Reg. 3(1)

Ex-ports (name and address) [REDACTED]

Name of owner of goods at time of export (if different to exporter) [REDACTED]

Consignee (name and address) [REDACTED]

Export Licensing Officer [REDACTED]

Registered Number of Licence [REDACTED]

Exported under Bank of Papua New Guinea  
 ‡ 1. General Authority  
 ‡ 2. Specific Authority Number

Bank in PNG in which currency proceeds will be sold or credited  
 Branch **MAYBANK, PORT MORESBY BRANCH**

\* Invoice value SA ..... **FOB US \$ 217,170.00**  
 (State whether f.o.b., c.i.f. or otherwise)

Buyer (if different to consignee) [REDACTED] **PAPUA NEW GUINEA**

MV YONG FENG  
 † Ship † Airline † Post      Port or airport of loading **CHINA**

Port or airport of discharge **CHINA**      Final destination of goods

\* Here state the value of the goods, that is to say—  
 (a) In the case of goods sold to overseas buyers before export—the net price according to the contract of sale; or  
 (b) In the case of goods shipped on consignment or any other goods as sold to overseas buyers before export—the estimated value of the goods in the principal markets of the country in which the goods are being consigned or shipped.  
 † Indicate the manner in which the goods are to be transported overseas by striking out whichever is inapplicable. If the goods are to be transported by ship or air/airfreight, also state name of ship or airline.

Marks and numbers	Number and kind of packages	Description of goods	Quantity (State unit)	** Unit price (a,b, SA
VARIOUS LOGS NO, MARKS, GRADING & SPECIES CODE		PAPUA NEW GUINEA ROUND LOGS	2,200 M3	AVERAGE FOB US \$ 98.71

PNGFA ID NO: [REDACTED]

MV YONG FENG      ETA: 13.03.2015

(FOR DEPARTMENTAL USE)

(a) I hereby grant a licence to export the goods specified in the foregoing application in one consignment, in the quantities, by the method of dispatch and from the place specified during the period from the date of grant of this licence to

(b) This licence is granted subject to the terms and conditions specified below/over



(STAMP) ..... 19.....  
 Export Licensing Officer

.....  
 hereby apply for an ordinary licence to export the goods as described herein and declare that I am the  
 exporter,  
 duly authorised agent of the exporter  
 and that the particulars shown herein are true and correct in every particular and that the value of above goods represents a consideration that is not less than the proper export value of these goods.  
 (Signature of exporter or agent of exporter)  
 Address (if signed by agent) .....  
 Date **16.03.2015**

\* Strike out whichever is inapplicable.  
 Govt. Print. — A3942/3 000. — 11.81

**NOTES:** (1) This licence to be returned to the Export Licensing Officer forthwith should the goods covered thereby be not exported in the stated manner or in full/total herein.  
 (2) Shortage of any of the goods specified herein should be notified forthwith in writing to the Export Licensing Officer.

**ATTACHMENT F: EXPORT PERMIT FOR NON-TIMBER FOREST PRODUCTS -  
TYPE 2 (sample)**



# MINISTER FOR FORESTS

To: The Regional Manager  
Customs Regional Office  
P.O. Box 441  
Rabaul  
East New Britain Province

CUSTOMS (Prohibited Exports) REGULATION  
CHAPTER No. 101 (Reg: Sec:2)

Our file reference

Friday, October 17, 2014

**Export Permit No. [REDACTED]**

I, Hon. Douglas Tomuriesa, MP and Minister For Forests hereby consent to the exports of the following produce.

**Exporter:** [REDACTED]  
**Producer:** n/a  
**TP/TL/TA/LFA No:** PNGFAL-[REDACTED]  
**Project:** n/a  
**Quantity (m<sup>3</sup>):** 63.916  
**Value (USD):** 27,483.88      Balsawood  
**Species:** As attached  
**Loading Ports:** Rabaul  
**Vessel:** Helene Rickmers  
**Departure Date:** 17-Oct-14  
**Destination:** China  
**Buyer:** [REDACTED]  
Beijing  
100012 CHINA



**Export Licence:**

  
**Hon. Douglas Tomuriesa MP,  
Minister for Forests**

PO BOX 5055, BOROKO, NATIONAL CAPITAL DISTRICT, PAPUA NEW GUINEA  
Telephone: (675) 327 7342 (Parliament) / 327 7918 / 920 (HQ Hohola)  
Facsimile: (675) 327 7480 (Parliament) / 325 5457 (HQ Hohola)



**ATTACHMENT G: FOREST INDUSTRY PARTICIPANT CERTIFICATE (Sample)**

**Schedule 1**  
**Forestry**

**INDEPENDENT STATE OF PAPUA NEW GUINEA**

**FORESTRY ACT 1991**

Act, Sec.111 Reg. 208 Form 209

**Certificate of Registration as Forest Industry Participant**

This is to certify that [REDACTED] Ltd of [REDACTED] Lae Morobe Province is registered as a Forest Industry Participant under Part IV of the Forestry Act 1991 in respect of the activities set out in Schedule 1 of this certificate.

Participant ID: [REDACTED]

Registration Number: [REDACTED]

Date of registration: **22 Aug 2014**

**SCHEDULE 1**

Harvesting of Forest Products  
Processing of Forest Products  
Sale of Forest Products  
Purchase of Forest Produce

  
.....  
**KANAWI POURU**  
**Managing Director**  
**PNG Forest Authority**

**IMPORTANT NOTICE:**

*The Regulations require a registered forest industry participant to notify any change of the particulars contained in this application for registration within 28 days of the change. Failure to do so renders an offender liable to a fine and to having its registration cancelled.*

*Section 112 of the Forestry Act provides that where the Managing Director is of the opinion that there has been a change in the circumstances of a person registered under the Act sufficient to justify cancellation of registration the Managing Director may refer the matter to the Board for consideration as to whether registration should be cancelled.*

**ATTACHMENT H: TIMBER AUTHORITY (Sample)**

INDEPENDENT STATE OF PAPUA NEW GUINEA

FORESTRY ACT 1991

Act, Sec. 87  
Reg. 159

FORM 155

**TIMBER AUTHORITY FOR DOMESTIC PROCESSING UP TO 5,000 CUBIC METRES  
PER YEAR**

Authority No.: TA [REDACTED]  
Project Area Name: [REDACTED] TIMBER AUTHORITY

I, Hon. Kila Hada, Chairman of the Committee responsible for forestry matters in the Central Provincial Government by virtue of the powers conferred by Section 87 of the Forestry Act 1991 and all other powers me enabling, hereby grant a Timber Authority to [REDACTED], a registered forest industry participant (Registration No. FI [REDACTED]) (referred to in this Authority as "the holder").

This Authority authorises the holder to carry out forestry operations in the project area described, and outlined in red on the map in Schedule 1 ("the Project Area") for the term specified in Schedule 2 subject to the Act and to the following terms and conditions -

- (a) the amount of allowable cut shall be as specified in Schedule 3; and
- (b) the holder must, within 21 days, lodge a performance bond in accordance with Section 98 of the Act for the amount specified in Schedule 4 (and if the performance bond is not lodged then this Timber Authority is void and of no effect); and
- (c) the holder must comply with the terms and conditions specified in the Schedules hereto.

Dated this 15<sup>th</sup> day of

JULY  
JUNE

2015.



(Signature of Chairman)

**ATTACHMENT I: FOREST CLEARING AUTHORITY (Sample)**

**SCHEDULE 1**

**INDEPENDENT STATE OF PAPUA NEW GUINEA.**

**Forestry Act 1991.**

Act, Sec. 90B(8).  
Reg. 263

Form 242

**FOREST CLEARING AUTHORITY TO CARRY OUT A LARGE SCALE CONVERSION OF  
FOREST TO AGRICULTURE OR OTHER LAND USE DEVELOPMENT.**

Forest Clearing Authority No: FCA [REDACTED]

Agriculture or other land use Development Project;

**[REDACTED] INTEGRATED AGRICULTURE PROJECT, KAIRUKU DISTRICT, CENTRAL PROVINCE.**

Pursuant to Section 90B(8) of the *Forestry Act* 1991, and all other powers it enabling, the Board hereby grants a Forest Clearing Authority to [REDACTED] [FI [REDACTED]] ("the Holder")

This Authority authorises the holder to carry out a large scale forest clearance for commercial agriculture or other land use development within the **10,530 hectares** of land area described, and outlined in red on the map in Schedule 1 ("the Project Area") for the term specified in Schedule 2 subject to the Act and to the following terms and conditions;

- (a) the holder shall, within 21 days, lodge a performance bond<sup>1</sup> in accordance with Section 98 of the *Forestry Act* 1991 for the amount specified in Schedule 3.
- (b) the holder shall comply with the terms and conditions specified in the Schedules herein.
- (c) the holder shall carry out the agriculture or other land use project in accordance with the approved land-use development plan and the approved implementation schedule contained in the holder's application for this Authority and as agreed to and as may be varied by the Board from time to time.
- (d) the holder shall comply with the conditions of any Permit, License or other Authority relating to the project and with the provisions of all Environmental and other relevant laws of Papua New Guinea.
- (e) the holder shall comply with such other conditions as are specified in Schedule 4 hereto.

Dated this 27<sup>th</sup> day of March 2015.

  
.....  
For the Board.

<sup>1</sup> If the Performance Bond is not lodged within 21 days and no application under Section 98(6) of the *Forestry Act* has been made within 21 days to the Board seeking an extension of time within which to lodge the Performance Bond then this Forest Clearance Authority is deemed void under Section 98(5) of the Act and thereby cancelled.

## ATTACHMENT J: FLITCH - Definition and Illustration

### FLITCH

Definition: Flitch is a large piece of timber having dimensions of more than 150mm x 150mm, sawn or hewn on at least two (2) sides and docked to required lengths.

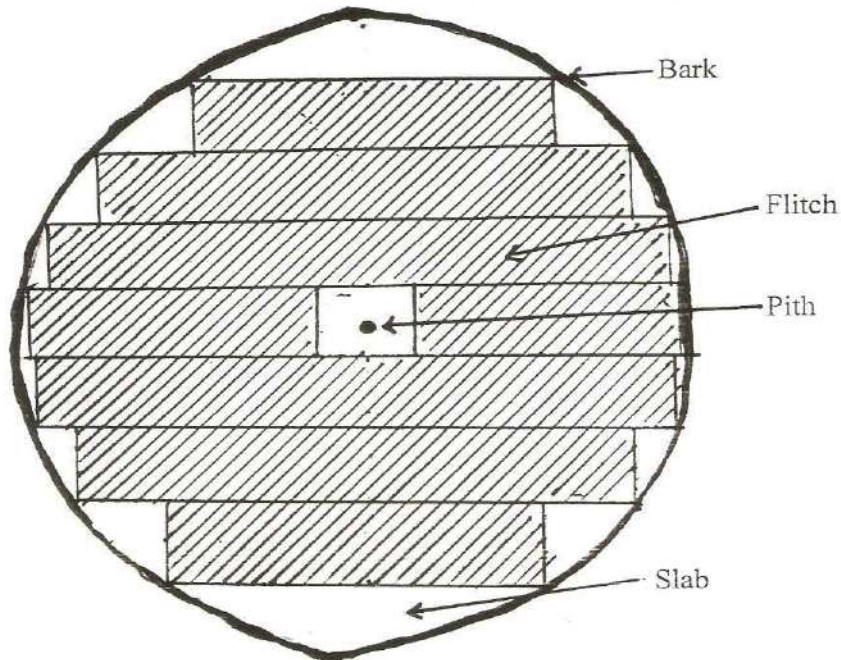

Note: A flitch is free from wane and pith and must measure more than 150mm x 150mm.

